

Operation Manual



Operation Manual

Nimble Hybrid Automated Disc Duplicator

Model #: NB25 /NB25-BR

Serial Number: _____

(The serial number is labeled on the rear panel of the device.)

PREFACE

Important Safety Instructions

For your safety, basic precautions should always be followed to reduce risk of damage, electric shock, fire, and personal injury. This includes the following:

- Read this manual carefully and follow all warnings and instructions.
- Operate the unit with only the proper electrical specifications as labeled on the device. Use only 3-wire extension cords that have 3-prong grounding plugs and 3-pole grounding receptacles that accept your device's plug. Make sure the device is connected to a known ground.
- Do not expose this unit to direct sunlight, rain, moisture, water, flammable material, gas, dust, dirt, smoke, pollution or abrupt humidity changes.
- Place this device on a steady level surface in an air-conditioned environment with sufficient ventilation. Do not move this device while the power is on. Handle with care.
- This device generates heat during the duplication process. Out-of-specification or unstable power supply may cause overheating, low productivity, increased failure rate, and damage to the device.
- Use a reliable power source with correct voltage and ample current supply. Give this device a dedicated power outlet. Do not share the outlet with other devices.
- Please make it a habit to always unplug the power cord before troubleshooting or performing maintenance. Always turn the power switch to the Off position when connecting the power cord.
- Do not attempt to disassemble this device or touch any of the moving parts. Refer servicing to qualified service personnel. Unauthorized disassembly or repair will void all warranty.

Acknowledgments

© 2012, Acronova Technology Inc. All rights reserved.

Notices: Reproduction, adaptation, or translation without prior written permission is prohibited.

Trademarks: Acronova, Nimbie, Genii, Xymba, DupliQ, and Apus are the trademarks of Acronova Technology Inc. All other products, brands, and trademarks are the property of their respective owners.

FCC Compliance: This equipment has been tested and found to comply with the limits for a Class B digital device, pursuant to Part 15 of the FCC Rules. These limits are designed to provide reasonable protection against harmful interference in a residential installation.

This equipment generates, uses, and can radiate radio frequency energy and, if not installed and used in accordance with the instructions, may cause harmful interference to radio communications. However, there is no guarantee that interference will not occur in a particular installation. If this equipment does cause harmful interference to radio or television reception, which can be determined by turning the equipment off and on, the user is encouraged to try to correct the interference by one or more of the following measures:

- Reorient or relocate the receiving antenna.
- Increase the separation between the equipment and receiver.
- Connect the equipment to an outlet on a circuit different from that to which the receiver is connected.
- Consult the dealer or an experienced radio/TV technician.

Use of shielded cables is required to comply with the Class B limits of Part 15 of the FCC Rules. You are cautioned that any changes or modifications not expressly approved in this manual could void your authority to operate and/or obtain warranty service for this equipment.

Limited Warranty (North America): The information contained in this document is subject to change without notice. Acronova Technology Inc. makes no warranty of any kind with respect to this information.

Acronova Technology Inc. guarantees this device for a period of one year from the date of delivery, free from defects in material and workmanship. In case of malfunction or fault, Acronova Technology Inc. will, at its option, repair or replace the product.

You must return the defective product, protected in the original packaging, with a valid RMA number, to an authorized dealer or reseller within the warranty period accompanied with the proof of purchase.

This warranty only covers parts made by Acronova Technology Inc. For parts made by other manufacturers, such as hard disks, and disc recorders, the original manufacturer's warranty applies.

This warranty will not cover abuse, misuse, alteration, modification, tampering, negligence, faulty installation, accidents, lack of reasonable care, unauthorized repairs or service, or if installed to any

device not provided with the product, or if the serial number label provided with this product has been broken or removed.

This warranty does not cover damages that occur in shipment, due to acts of God. All repairs and replacement services shall only be handled by Acronova Technology Inc, and by authorized service centers. Parts used for replacement are covered only for the remainder of the warranty period.

Acronova Technology Inc. disclaims all implied warranties on this product, including without limitation warranties of merchantability, performance, and fitness for a particular purpose.

In no event will Acronova Technology Inc. be liable for direct, indirect, special, incidental, tort, economic, contingent or consequential damages resulting from any defect in this product or its documentation, including, without, limitation, damages or costs relating to the loss of data, profits, business or goodwill, even if Acronova Technology Inc., its authorized dealers or resellers have advertised the possibilities of such damages. In no case shall Acronova Technology Inc.'s liability exceed the amount paid by the user of this product out of which such claim arose.

Any written or oral information or advice given by the dealer, reseller, agent, sales representative, or employee of Acronova Technology Inc. will in no way increase the scope of this warranty nor should you rely on such oral or written communication.

Technical Support: For technical support and assistance, please contact your local dealer.

For additional information regarding optical disc duplication, printing, and management please visit our website. We value your comments and suggestions and thank you for your purchase.

Acronova Technology, Inc.
<http://www.acronova.com>

Table of Contents

Preface	2
Specifications	6
Unpacking Your Package	7
Package Contents.....	7
Getting Familiar with the Device	9
A Look at Nimbie Hybrid.....	9
Rear View.....	10
Control Panel.....	10
LED Indicators	11
Before Getting Started	12
Tips for Handling Optical Discs.....	12
What You Need to Start a Disc Duplication Session.....	12
Important Tips for Loading Discs to Nimbie Hybrid.....	12
Rejected Discs.....	12
More Than 30 Discs in One Session.....	13
Automated Multiple-Master-Disc Duplication (Standalone Mode).....	14
Disc Verification (Standalone Mode).....	14
Write Speed: Production Rate vs. Duplication Quality.....	14
Handling Disc Write Failures.....	15
Installation	16
Finding a Place for Nimbie Hybrid.....	16
Using the Detachable Legs.....	16
Nimbie Hybrid Installation.....	16
Software Installation (PC-Connected Mode).....	17
Operation Quick Guide	19
Standalone Application.....	19
PC-Connected Application.....	22
Appendix	23
Nimbie Hybrid Maintenance.....	23
Choosing Reliable Blank Discs.....	23
Disc Separation.....	23
The Quality of the Master Disc Counts.....	24
Writing Speed.....	24
Frequently Asked Questions	25

SPECIFICATIONS

Disc Recorder	One CD/DVD recorder (NB25); One Blu-ray/CD/DVD recorder (NB25-BR)
Input Capacity:	30 discs; 100 discs using extension rods (increased capacity using non-stop refill)
Output Capacity:	Dependent capacity (finished discs are placed in front of the unit, in a separate container, or Disc Storage Bin)
Reject Disc Capacity:	5 discs without legs; 30 discs using legs
Write Speed:	CD-R: 40X; CD-RW: 32X; DVD±R: 18X; DVD±R Dual: 10X; DVD-RW: 6X; DVD+RW: 8X Blu-ray: 4X (NB25-BR)
Operation Method:	Standalone or PC-connected
Control Panel:	High-Speed, Normal-Speed, Function, Test/Abort; with corresponding LED Indicators
Disc Size:	120 mm in diameter
Operation Temperature:	42°F to 86°F (6°C to 30°C)
Humidity:	5% to 85%, no condensation
Certification:	CE and FCC; power adaptor is UL approved
Dimensions:	7-3/4" x 8-1/2" x 15-3/8"; 19.5 x 21.3 x 39 cm
Weight:	3 kg; 6.5 lbs (varies upon configuration)
Power:	100 to 240VAC; 50 or 60 Hz

*Specifications are subject to change without notice.

UNPACKING YOUR PACKAGE

Congratulations on purchasing the Nimbie Hybrid Automated Disc Duplicator. Nimbie Hybrid is a state-of-the-art, automated, optical disc duplicator, which can be operated as a standalone or PC-connected autoloader.

Nimbie Hybrid has a 30 disc capacity, which can be increased to 100 by using storage extensions. It can also detect faulty discs and separate them from a duplication session. Depending on the configuration of your device during purchase, it may come with a CD/DVD (NB25) or Blu-ray recorder (NB25-BR).

Please read this manual carefully before using Nimbie Hybrid. This user guide contains all the information on its operation and maintenance. For additional information regarding optical disc duplication, printing, and management please visit our website. We value your comments and suggestions and thank you for your purchase.

Package Contents

Before opening the package, carefully inspect for any damage. If there is any sign of damage, contact the shipping company and your local dealer immediately.

Save the packing materials in case you need to ship or return your product. The original packaging will ensure the product is protected during transportation. Returning goods without the original packaging may not protect the product during transportation, and will void your warranty.

Once you have removed all the parts contained in your package, please check if any parts are missing or damaged. If any part is missing or damaged, contact your local dealer immediately.

The items listed below should be included in the package:

- One Nimbie Hybrid Automated Disc Duplicator
- One Power Cord
- One Power Adapter
- One USB Cord
- One Spindle Box (serves as the Finish Disc Bin)
- Three Extension Rods (attached to the underside of Nimbie)

Hybrid's lid)

- One Alignment Pad
- Four Legs
- One Installation Disc (includes device driver and software)
- One Operation Manual
- Two Software Manuals

GETTING FAMILIAR WITH THE DEVICE

Nimbie Hybrid is a versatile device. You can utilize Nimbie Hybrid as a Standalone duplicator or a PC-connected autoloader.

Depending on the configuration during your purchase, your Nimbie Hybrid may come with one of the following optical disc recorders:

- Nimbie Hybrid NB25: CD/DVD recorder
- Nimbie Hybrid NB25-BR: Blu-ray/CD/DVD recorder

A Look at Nimbie Hybrid

The figure to the right shows Nimbie Hybrid with a spindle box in front of it to collect and stack finished discs.

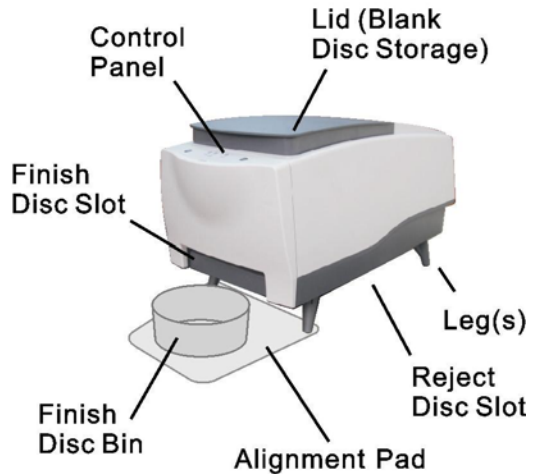

- **Lid (Blank Disc Storage)**
Open the lid to access the blank disc storage area.
- **Control Panel**
Located on the top front of Nimbie Hybrid, the control panel contains the LED indicators and operation buttons.
- **Legs**
Use the four legs included with your Nimbie Hybrid to provide space underneath for rejected discs.
- **Reject Disc Slot**
The rejected discs will slide out from the Reject Disc Slot at the bottom of the unit. Always allow space beneath Nimbie Hybrid to accommodate rejected discs.
- **Finish Disc Slot**
Finished discs will exit from this slot.
- **Finish Disc Bin**
This bin serves as the storage container for receiving and stacking completed discs. As illustrated, a spindle box serves as a good Finish Disc Bin.

- **Alignment Pad**

Use the pad to appropriately position the Finish Disc Bin under the Finish Disc Slot.

Rear View

- **Power Switch**

Turn Nimbie Hybrid on and off.

- **Power Socket**

Use the provided power cord to connect Nimbie Hybrid to a wall outlet.

- **USB Port**

Connects Nimbie Hybrid to the host PC.

- **Ventilation**

This allows heat to escape. Do not block this otherwise the unit may overheat.

- **Kensington Security Slot**

Security lock anti-theft system.

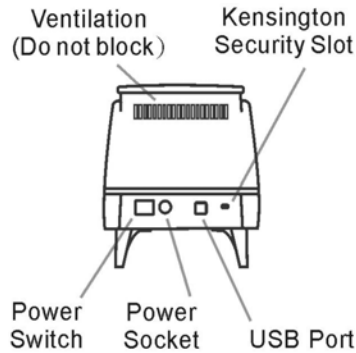

Control Panel

There are operation buttons and LED indicators on Nimbie Hybrid's control panel as illustrated to the right.

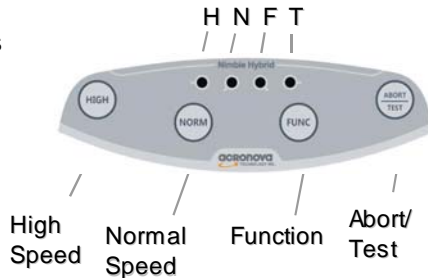

- **High-Speed Duplication**

Press to start the duplication process at the highest possible write speed to produce discs at the maximum production rate.

- **Normal-Speed Duplication**

Press to start normal speed duplication. This increases quality but decreases output rate. Recommended for audio and video discs.

- **Function Key**

Press this button to activate or deactivate disc verification during the duplication process.

- **Test/Abort**

Press to abort the current duplication process or to start a duplication simulation.

Important:

The High-Speed Duplication mode will use the maximum recorder speed but may be limited by the write speed of the disc.

LED Indicators

Nimbie Hybrid's status is reflected by the LED indicators. When turned on, it will enter initialization indicated by a flashing green ready light. When initialization is complete, the ready light will change to steady green. The table below describes the meanings of the LED indicators.

H	N	F	T	Description
●	●	●	●	The Power Switch Is in the Off Position
⇒	⇒	⇒	⇒	Device Initialization
●	●	●	○	Ready Mode
◎	●	●	○	High-Speed Duplication
●	◎	●	○	Normal-Speed Duplication
◎	●	○	○	High-Speed Duplication with Disc Verification
●	◎	○	○	Normal-Speed Duplication with Disc Verification
●	●	◎	○	Disc Verification / Simulation
⇒	⇒	⇒	○	Erasing Rewritable Disc
●	●	●	◎	Error Encountered
●	●	○	○	Function Key Enabled

○: Lit

●: Off

◎: Flash

⇒: Running

BEFORE GETTING STARTED

Tips for Handling Optical Discs

Never touch the printable or data surface of the discs, as it may decrease quality and disc lifespan. Refer to the arrows on the illustration to the right. Always handle discs from the outer edge or the center hole.

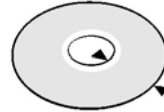

What You Need to Start a Disc Duplication Session

The Nimbie Hybrid is a convertible duplicator. You will need the following to start a duplication session:

- **Master Discs**
The original disc providing the source of data for a duplication session.
- **Blank Discs**
The disc that Nimbie Hybrid will write the source data to during a duplication session.

Important Tips for Loading Discs to Nimbie Hybrid

When the disc loader is empty, do not attempt to load many discs at once.

First, carefully load only one disc into the disc loader and assure it is firmly resting on the three wheels seen in the illustration to the right. You may then gradually load additional discs on top of the first disc, until the loader is full.

Nimbie Hybrid processes discs in a First In, First Out (FIFO) sequence. During a duplication session, if a disc refill is required, before the loader becomes empty, gently load additional discs.

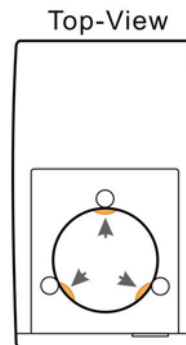

Rejected discs come out beneath the unit

Rejected Discs

Nimbie Hybrid is designed to have Rejected Discs come out underneath the unit. Do not block the Reject Disc Slot.

Periodically remove rejected discs so that there is room to accommodate more discs or raise Nimbie Hybrid using the provided legs to increase space underneath for more discs.

Important:

Nimbie Hybrid will stop operation if rejected discs cannot go through the Reject Disc Slot.

More Than 30 Discs in One Session

Using the extension rods, Nimbie Hybrid can process 100 discs without refilling. To increase capacity to 100 discs, please follow the instructions below:

- 1) Open the Blank Disc Storage Lid.
- 2) Remove the extension rods from the lid's underside.
- 3) One after another align the rods into the three holes on the disc loader, then, gently turn the rods counterclockwise to make sure that they are firmly attached.
- 4) Use a suitable box to raise Nimbie Hybrid approximately 96 mm high to accommodate for the output of 100 discs.
- 5) Use the alignment pad to appropriately position the Finish Disc Bin below the Finish Disc Slot. The Finish Disc Bin may be a spindle box or a container with enough depth to accommodate 100 discs in a session.

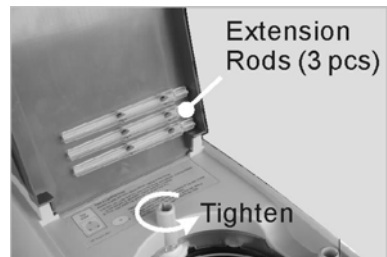
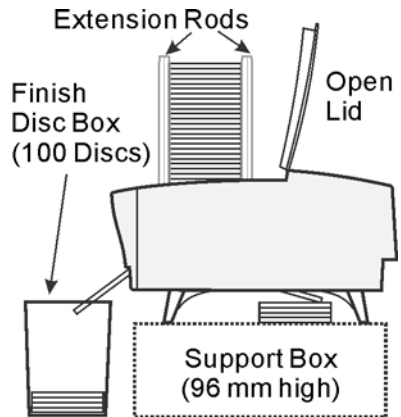

Since Nimbie Hybrid is equipped with a FIFO (First-In-First-Out) disc loader, you may simply refill discs before the disc loader becomes empty. This will allow an unlimited number of additional discs to be processed in one session, as long as the Finish Disc Bin is continually

emptied.

To remove the extension rods from the disc loader, turn the rods clockwise and pull them upward vertically. When not using the rods, return them to their original position on the lid's underside.

Automated Multiple-Master-Disc Duplication (Standalone Mode)

While Nimbie Hybrid is used as a standalone duplicator, it not only performs one-to-multiple, but also multiple-to-multiple disc duplication. Whenever Nimbie Hybrid detects a non-blank disc in a recorder, a disc image will be written to the built-in hard disk. The disc image is then used to duplicate all the following blank discs, until another master disc is detected or the loader becomes empty.

When another non-blank disc is detected, a new disc image will be written to the built-in hard disk. The previously stored image will be overwritten and the new image will be used for disc duplication.

Do not use rewritable discs as a master disc, since Nimbie Hybrid is designed to always erase rewritable discs before attempting to write data to them.

Disc Verification (Standalone Mode)

Nimbie Hybrid is not only able to verify each duplicated disc with the source disc image during a duplication cycle, it can batch verify a stack of discs with a master disc. Disc verification involves reading and comparing the duplicate disc image with the master disc image on the hard disk.

Disc verification is performed according to the disc data format. For data disc verification, both the read and comparison process will be performed. However, due to the limitation of industry standards, for audio disc verification it will only perform the reading check without the comparison process.

Write Speed: Production Rate vs. Duplication Quality

By pressing the appropriate button, Nimbie Hybrid as a standalone autoloader can perform High-Speed and Normal-Speed Duplication accordingly. High-Speed Duplication writes to discs at the highest possible speed according to the recorder and blank disc characteristics.

Although High-Speed Duplication takes less time to write to a disc,

and produces more discs per hour than Normal-Speed Duplication, a higher failure rate may be encountered, especially when the blank disc quality is not good.

Most users choose High-Speed Duplication, while professional users prefer Normal-Speed to duplicate audio and video discs, for better quality.

When quality is critical, please activate the Verify Disc mode to have Nimbie Hybrid read and verify each duplicate disc with the source image immediately after the disc is duplicated.

Handling Disc Write Failures

Some discs may be defective and failed during a write session. A failed disc will be sent to the Reject Disc Slot.

To avoid excessive disc failure, Nimbie Hybrid is designed with the following rules when disc failure is encountered:

- In a normal duplication session if the recorder continuously fails to write to ten discs in sequence, this recorder will be deactivated.
- Nimbie Hybrid will halt the active duplication session and the LED indicator status will show “error encountered”.

To resume operation from an error, carefully check for and resolve any noticeable problems, and press the button for the desired duplication speed to resume the session.

Important:

In case Nimbie Hybrid has been turned off, always wait for 30 seconds before turning it back on. Then, reload the master and blank discs and press the appropriate button to start a new job.

INSTALLATION

Finding a Place for Nimbie Hybrid

Nimbie Hybrid should be placed on a fairly level surface, firm enough to support the unit and discs. Always allow ample workspace for your operation, with easy access to the blank and finished discs.

Do not expose the unit to direct sunlight or high humidity, as it may cause the unit to malfunction.

If you desire, Nimbie Hybrid can be placed on a raised block so there is ample room to receive discs from the Finish Disc Slot. Please refer to the “More Than 30 Discs in One Session” section for details.

Using the Detachable Legs

Nimbie Hybrid is designed to work either with or without detachable legs. Without the legs, the Reject Disc Slot (recession) on Nimbie Hybrid’s base will hold up to 5 rejected discs.

If your application doesn’t involve rejected discs, you may use Nimbie Hybrid without the legs. It is, however, recommended to use the legs when possible.

The legs will raise Nimbie Hybrid providing sufficient room to accommodate additional rejected discs, as well as easier access beneath the unit.

Attaching legs to Nimbie Hybrid is simple. Inserting one leg after another on Nimbie Hybrid’s base, match the leg to Nimbie Hybrid (A to A’) and gently snap the leg into the receptacle (B to B’) until it is firmly attached.

To remove the legs, gently press the notch (N) and pull it outward from the receptacle (B’).

Nimbie Hybrid Installation

Follow the steps below to complete Nimbie Hybrid’s hardware installation:

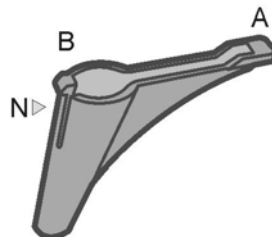
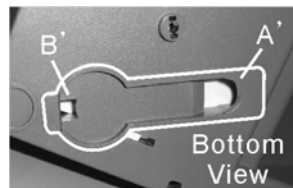

- 1) Place Nimbie Hybrid on level surface so that it stands firmly on its legs.
- 2) Place the spindle box that came with the unit in front of Nimbie Hybrid. Use the alignment pad to appropriately position the spindle box under the Finish Disc Slot.
- 3) Use the power cord that came with the unit to connect Nimbie Hybrid to a wall outlet with a reliable power supply.

You have now successfully completed the installation of Nimbie Hybrid.

Software Installation (PC-Connected Mode)

Nimbie Hybrid requires a device driver to be installed before it can work properly with the application software. Before starting the application software installation, the device driver must be installed.

System Requirements

- Microsoft® Windows XP, Vista, 7
- Pentium III 700Mhz (Pentium IV 1.6Ghz Recommended)
- 512MB RAM (1GB RAM Recommended)
- 1024x768 display with 16-bit video card
- Optical disc drive (to install the device driver and software from the installation disc)
- USB 2.0 interface

Device Driver Installation

Follow the steps below to complete device driver installation:

- 1) Connect the power cord to Nimbie Hybrid and a wall outlet.
- 2) Turn on the host computer, which is connected to Nimbie Hybrid via USB cable.
- 3) Insert the provided installation disc into your optical drive on PC.
- 4) Connect the USB cable to both Nimbie Hybrid and your PC.
- 5) Turn Nimbie Hybrid's power switch to the On position.
- 6) Wait patiently until the initialization is complete.
- 7) Windows will inform you that it has found new hardware. Browse the installation discs and choose ACAL764.inf as the device driver.
- 8) If the Windows System doesn't show the "Found New Hardware" message window, you can go to Windows Device Manager and install the autoloader driver manually.

You may now proceed to install the application software.

Note:

Go to the Device Manager in Windows Operating System to verify that the device driver has been successfully installed.

Application Software Installation

Nimbie Hybrid application software is included in the installation disc. Follow the steps below to complete the installation:

- 1) Insert the installation disc into an available optical drive on PC.
- 2) After the Main Menu is launched, click Install and follow the on-screen instructions to get application software installed.

Note:

For Windows Vista user, click Run SETUP.EXE on AutoPlay window to start installation. When the User Account Control screen pops up, click Continue.

- 3) After the application software has been properly installed, software shortcuts shall appear on desktop.
- 4) Remove the installation disc and keep it safe for future use.

OPERATION QUICK GUIDE

Standalone Application

Nimbie Hybrid can be used as a standalone device, when USB cable is removed from the device.

Turning Nimbie Hybrid On

Follow the steps below to get your Nimbie Hybrid ready:

- 1) Connect the power cord to Nimbie Hybrid and a wall outlet.
- 2) Turn Nimbie Hybrid's power switch to the On position.

Nimbie Hybrid will enter the initialization process and shall remove any discs inside the optical recorder. Be patient until the initialization process has completed.

When initialization is complete, you will see the "ready" indicator light up signaling that Nimbie Hybrid is ready for a disc operation.

Abort a Running Operation

To abort a duplication session, press and hold the Test/Abort button for two seconds. If the recorder is currently writing to disc, Nimbie Hybrid is designed to abort the duplication session after the recorder has completed writing to disc.



Important:

Turning the power switch to the Off position will immediately terminate the active duplication session, damaging any disc in the process of being written to. Only turn off the power in case of emergency.

Start a Duplication Session

High-Speed Duplication produces more discs per hour, yet Normal-Speed assures duplicated disc with better quality especially for audio and video discs.

Follow the steps below to start a one-to-multiple disc duplication session:



**High Speed
Copy**



**Normal Speed
Copy**

- 1) Load the master disc into the disc loader.
- 2) Load the desired quantity of blank discs on top of the master into the disc loader.
- 3) Press either the High or Normal-Speed Duplication button to start. Nimbie Hybrid will run the operation until the disc loader is empty.

Important:

During duplication whenever a rewritable disc is detected, Nimbie Hybrid is designed to always erase the disc. Do not use rewritable discs as master discs because the data on the disc will be erased.

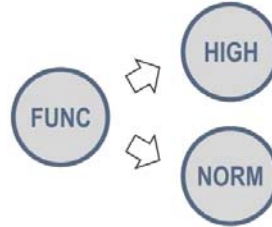

Important:

To verify your written data, press the Function Key, then press the High or Normal-Speed button to start.

Important:

The Nimbie Hybrid will save the latest master disc image on the hard disk until a new master disc has been read. This is the case even if the Nimbie Hybrid has been turned off or restarted after a previous session has completed.

If using multiple master discs to produce different quantities of duplicate discs, repeat steps 1 and 2 to load additional sets of masters and blank discs. Then, press the High or Normal-Speed button to start duplicating discs. The illustration below shows an example of three disc sets, stacked in interleave mode with one on top of another, for multiple-to-multiple duplication.

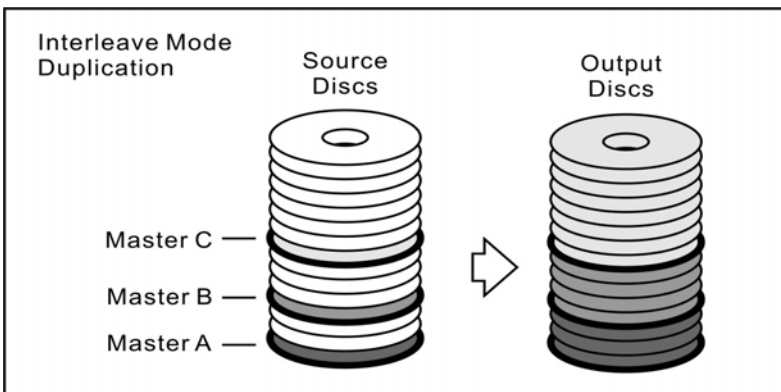

Duplication Simulation

This mode is used to test discs for writing by emulating a duplication session without actually writing to the discs. Follow the steps below to start a duplication simulation session:



- 1) Load the master disc into the disc loader.
- 2) Load the desired quantity of blank discs on top of the master disc.
- 3) Press the Test/Abort button to start. Nimbie Hybrid will run the operation until the disc loader is empty.

Important:

Duplication simulation will not work with DVD+R, DVD+RW and DVD+R DL discs. When a DVD+ disc is detected it will be rejected.

Erase a Stack of Rewritable Discs

This operation erases a stack of rewritable discs for future use:



- 1) Load the rewritable discs you would like to erase into the disc loader.
- 2) Press the Test/Abort button to start. Nimbie Hybrid will erase discs until the disc loader is empty.

Verify a Stack of Discs

This operation verifies a stack of duplicated discs against a master disc. Follow the steps below to start the verification process:

- 1) Load the master disc and the discs you would like to verify.
- 2) Press the Function Key and press the Test/Abort button to start.



Turning Nimbie Hybrid Off

To turn Nimbie Hybrid off, turn the power switch to the Off position. In case there is a duplication session underway, abort or wait until it has completed.

Although it is fine to leave the power cord plugged in, it is recommended that you unplug the cord for increased safety when Nimbie Hybrid is not used for extended periods of time.

PC-Connected Application

With the USB cable connected to host computer and Nimbie Hybrid, it can be operated as a PC-connected device. Follow the steps below to get your Nimbie Hybrid ready.

Turning Nimbie Hybrid On

- 1) Connect the power cord to Nimbie Hybrid and a wall outlet.
- 2) Turn on the host computer, which is connected to Nimbie Hybrid via USB cable.
- 3) Connect the USB cable to both Nimbie Hybrid and your PC.
- 4) Turn Nimbie Hybrid's power switch to the On position.
- 5) Nimbie Hybrid will enter the initialization process. Be patient until the initialization process has completed. When initialization is complete, you will see the "ready" indicator light up signaling that Nimbie Hybrid is ready for a disc operation.
- 6) Launch application software "QQboxx Pro 3" to get Nimbie Hybrid operated.

Refer to application software user's guide for operation directions

For details on software operation, please check out application software user's guide.

Turning Nimbie Hybrid Off

Unplug the USB cable which connects your host PC and Nimbie Hybrid. Then, turn the power switch to the Off position. In case there is a duplication session underway, abort or wait until it has completed.

Although it is fine to leave the power cord plugged in, it is recommended that you unplug the cord for increased safety when Nimbie Hybrid is not used for extended periods of time.

APPENDIX

Nimbie Hybrid Maintenance

Periodically cleaning the device will ensure proper performance. Follow the steps below to maintain Nimbie Hybrid:

- 1) Turn the power switch to the Off position.
- 2) Remove the master and blank discs.
- 3) Unplug the power cord from the wall outlet.
- 4) Clean Nimbie Hybrid using a lint-free cloth moistened with warm water.
- 5) Dry the unit immediately with a dry lint-free cloth.

Choosing Reliable Blank Discs

The quality of a recordable disc depends on its chemical and coating technology. There are a variety of discs with various degrees of disc quality available on the market. If you encounter a high failure rate, please try a different type, speed, or brand of disc.

There are many different brands, speeds and CD/DVD recordable media formats on the market. We do our best to test certain media types. It is impossible for us to guarantee that all discs will be compatible.

Please choose a blank disc that is most suitable for your application. You may contact your local dealer for advice on the best suitable blank disc for your system. In addition, we suggest users to test blank discs by using disc simulation before actually writing to discs.

Important:

As with blank discs, the quality and the data format of the master disc play a critical role in the duplication process

Disc Separation

Certain blank discs may tend to stick to each other or may be difficult to separate. Avoid these types of discs. Nimbie Hybrid is equipped with a patent pending disc separator, which handles discs that adhere to each other better than traditional autoloaders. However, it is strongly recommended that you separate or loosen blank discs from each other before use.

The Quality of the Master Disc Counts

As with blank discs, the quality and the data format of the master disc play a critical role in the duplication process. If you encounter difficulties try Normal-Speed Duplication to increase quality and lower failure rate.

Writing Speed

The recorder will automatically adjust the writing speed according to the disc quality. The system will monitor and automatically adjust the writing speed as the optical laser moves from the inner ring to the outer ring, up to the selected speed. The recorder's maximum speed may never be reached if a lower grade disc is used.

At the maximum speed, for a single recorder, duplicating a 4.7 GB DVD should not take more than 8 minutes. Please check both the quality of the blank and the master disc if the duplication process takes more than 8 minutes for a single disc. Use a reliable master disc for testing purposes. You should also try different specification and brands of blank discs.

You should also check the power supply's voltage and amperes. Insufficient power supply may decrease output rate or increase failure rate.

As a general rule, a lower writing speed will improve quality. When creating audio and video discs a lower writing speed is recommended to assure quality.

FREQUENTLY ASKED QUESTIONS

Why is my duplication failure rate so high?

- Try a lower writing speed using Normal-Speed Duplication.
- Use a different brand of blank discs.
- Check the power source.

Why do my discs get stuck in the disc loader during the duplication process?

- Check to see if the disc is the standard size (120mm).
- Make sure discs are level in the loader.
- Reduce the quantity of discs per load. Some discs may bend from the weight of the discs placed on top of them.
- Use a different brand of blank discs.

Why won't the power switch work all the time?

- Allow a 30 second interval when switching the power on and off.

Why does the autoloader fail to pick up the disc?

- Check to see if the disc is the standard size (120mm).
- Make sure the discs are not bent or damaged.

Why is the autoloder dropping two or more discs at a time?

- Check to see if the disc is the standard size (120mm).
- Make sure the discs are level when inserted.
- Separate or loosen the discs from each other before use.
- Use the same brand of discs. Do not mix disc types or brands.
- Reduce the quantity of discs per load. Some discs may bend from the weight of the discs placed on top of them.
- Use a different brand of blank discs.

How can I restart or reset Nimbie Hybrid when it is not working properly?

- Turn the power switch to the Off position and back to the On position after waiting 30 seconds. If this does not solve the problem, please contact your dealer or authorized service center.

Nimbie Hybrid is showing an error on the LED display. What should I do?

- If Nimbie Hybrid is showing an LED error please remove all the discs in the loader. Be sure to check for any discs that may be stuck inside the unit.
- You can also turn the power switch to the Off position and back to the On position after waiting for 30 seconds.
- Nimbie Hybrid may continue to show an LED error. After trying the above suggestions with no result press and hold the FUNC button until you see the LED display change. Please record the LED message.
- Next press and hold the TEST button until the LED display changes again. Please record the new LED message. Please provide this information to the dealer along with the Nimbie Hybrid serial number located on the bottom of the unit.

(This page is intentionally left blank.)

Acronova Technology, Inc.
<http://www.acronova.com>
Manual Ver.: 1.0, February 2012
Part #: 711-NT25-9AC6-1